

HYBRID'S ANGELS

High-Level Design

Hybrid Electric Motorcycle

Stephen Govea; Eric Schafer; Jean Whitney; Ravi Fernando; Jeffrey F. Wolanin

10/28/2008

This document details the preliminary high-level design for the Hybrid's Angels Senior Design Project. It will address broad design requirements, design decisions, and questions that still need to be answered.

Contents

1	Introduction	4
2	Problem Statement and Proposed Solution	4
2.1	Problem Statement	4
2.2	Proposed Solution	4
3	System Description and Block Diagram	5
3.1	System Description	5
3.2	Block Diagram	6
4	System Requirements	6
4.1	Overall System	6
4.2	Subsystem Requirements	6
4.2.1	Generator	6
4.2.2	Charging Circuitry	7
4.2.3	Control System	7
4.2.4	Monitoring System	8
4.3	Future Enhancement Requirements	9
5	High Level Design Decisions	9
5.1	Generator	9
5.2	Charging circuitry and Power Supply for Electronics	9
5.2.1	Power Supply for Electronics	9
5.2.2	Charging Circuitry	12
5.3	Control System	14
5.4	Monitoring System	16
5.4.1	Data Storage Subsystem	16
5.4.2	Data Analysis Subsystem	16
6	Open Questions	16
7	Major Component Costs	17
8	Conclusions	17
9	References	17
9.1	Lightening Rider's HLD	17
9.2	Generator	17

9.3	Transformer Web Sites	17
9.4	72V DC Charger for Electric Vehicles	18
9.5	Stainless Steel Prices	18
9.6	Charging Circuitries	18
9.7	Electronics Parts.....	18

1 INTRODUCTION

From August 2007 to May 2008, a group of senior electrical engineering majors at the University of Notre Dame began construction on a series hybrid electric motorcycle. Over the course of the year, they successfully converted a 1983 Yamaha Seca into a battery powered vehicle; however, they were unable to meet the ambitious goal of mechanical power system hybridization. In this proposal, Hybrid's Angels will delineate a plan to realize this goal in addition to fixing and enhancing current issues with the motorcycle's current design.

2 PROBLEM STATEMENT AND PROPOSED SOLUTION

2.1 PROBLEM STATEMENT

The phrase "going green" has gained widespread popularity in recent years. As uncertainty mounts about the effects of carbon emissions on the earth's future, increased pressure is falling upon individuals around the world to reduce their carbon footprints. This can be accomplished in a wide variety of ways from an increased devotion to recycling to simply turning off a light when not in use. Energy conservation and decreased emissions are more important now than ever because evidence of the negative effect of the world's hitherto wasteful nature is finally beginning to manifest itself. One of the major sources of this waste is a product that has become fundamental to Americans' daily activities – the automobile. Automobiles have been a staple of transportation for decades, and the carbon dioxide and carbon monoxide that they billow through their exhausts is a colossal part of the problem. A great deal of stress has been placed upon auto manufacturers to trim their vehicles' emissions, and thus far the most popular response has been the introduction of the hybrid vehicle. Although certainly not the solution to all of the energy ills, hybrid technology will act as a critical transition technology until cleaner, more efficient sources are implemented.

2.2 PROPOSED SOLUTION

While hybrid vehicles are not completely independent of fossil fuels, they are much more "green" than gasoline powered engines. The electricity used to power the batteries in a hybrid is likely to come from a power plant that burns fossil fuels, but even that situation is much more efficient and environmentally friendly than the combustion engine of a car. In addition, a hybrid vehicle will not produce any emissions while running off the batteries. So why not just build an electric vehicle? Range and charging time of current electric automobile technology cannot compete with traditional gasoline powered engines used in most cars. A hybrid is therefore the best solution because it is a compromise between current gasoline powered automobiles and the emission-free vehicles of the future.

Last year, a group of senior electrical engineering majors, the Lightning Riders, built a prototype electric motorcycle. For this group's project, they will modify and improve the electric motorcycle built by the Lightning Riders by turning it into a hybrid motorcycle.

3 SYSTEM DESCRIPTION AND BLOCK DIAGRAM

3.1 SYSTEM DESCRIPTION

Hybrid's Angels' hybrid motorcycle will utilize a series hybrid configuration. This configuration begins with power from a standard 120VAC wall outlet being sent into a specially designed circuit. This circuit will be created to convert the AC waveform into a DC signal of approximately 90V. This 90V of direct current will be used to charge the 72V stack of batteries. When the batteries are fully charged, the group will take the wall input plug and insert it into the generator.

The generator produces the same waveform as the wall output but it is mobile because it runs off of gasoline power. Therefore, we can use the same charging circuit to charge the batteries while the motorcycle is running. The generator will be electric start, meaning that we will be able to control its operation with a microcontroller.

In operational mode, the batteries will be used to power two things. First and foremost, the 72V battery stack will drive the analog motor controller. This motor controller drives the electric motor, which in turn rotates the wheel via a gear shaft. It is operated by the bike's throttle. This entire system was put in place by the Lightning Riders and will not be our biggest concern. Since the original design suffered a slight flaw when the electronic circuitry was being powered by two batteries in the stack, the group will need to explore a more efficient way to power these onboard electronics, which include the microcontroller, LED display, sensors, and other necessary onboard electronic components.

Of more interest to the group will be the electronic system. There will be a system of sensors placed all over the bike – temperature on the batteries, current from the batteries, and voltage remaining on the batteries. All of these data will be fed into the microcontroller. Based on these data, the control module will make real-time decisions about ways to increase the bike's energy efficiency. A monitoring module will also receive the data from the sensors, but its primary focus is to store that data for future analysis.

3.2 BLOCK DIAGRAM

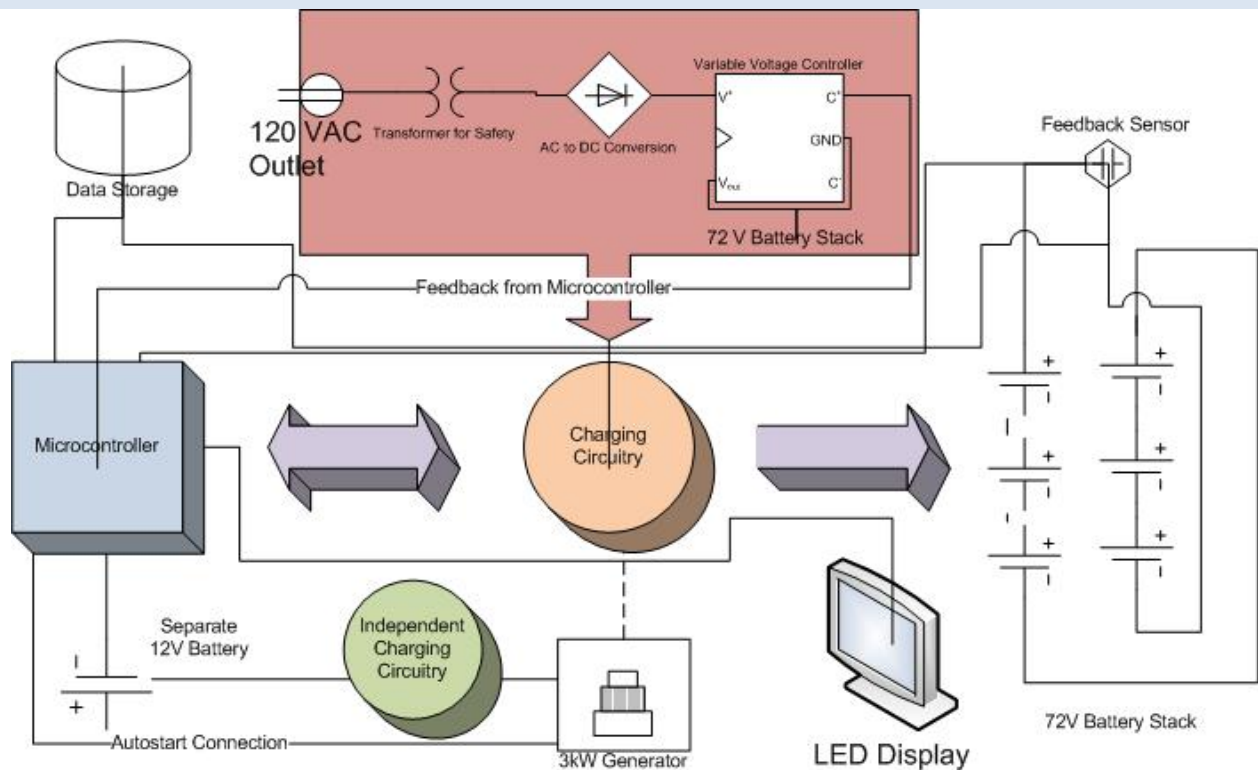

Figure 3.2a: Block Diagram Design

4 SYSTEM REQUIREMENTS

4.1 OVERALL SYSTEM

Hybrid's Angels' overarching goal will be to make a working hybrid motorcycle. Still, the group intends to fix and improve some of the features, which were implemented to varying degrees of success in the Lightning Riders' model. In May, Hybrid's Angels expect to demonstrate a fully functional hybrid motorcycle with top speeds of at least 50 miles per hour and a range of at least 20 miles before refueling and/or recharging.

4.2 SUBSYSTEM REQUIREMENTS

4.2.1 GENERATOR

The generator will have to be gas-powered and mobile. Hybrid's Angels have decided to use a single generator mounted on the back rather than the dual-generator saddle-bag configuration, so size and balance are of the utmost importance. In addition, the group wants to use an electric start generator; this is so that the microcontroller can send a signal to start the gas engine inside. Finally, it has to

output 120VAC, and the group will have to be able to draw a continuous 20 amps in order to charge the batteries to the ideal specifications.

4.2.2 CHARGING CIRCUITRY

Ultimately, the overlying goal in the creation of the charging circuitry will be to develop a system that charges the 72V battery stack as quickly as possible while maintaining an appropriate level of safety. Appropriate measures should be considered not only to protect the user but also the integrity of the batteries. As a goal of this project is to show that a series hybrid system is ready, viable solution, the charging circuitry must interface with a common electrical socket (120 VAC, 60 Hz). In order to enhance the charging speed, this circuitry will be duplicated in order to draw as much power as possible without tripping a standard household breaker.

From the outlet, a mechanism, such as a fuse and or transformer, must be present so as to prevent the high voltage AC signal from destroying the circuitry. This circuitry will then require conversion circuitry to transform the AC signal to a stable DC one which can ultimately be used to charge the 72V battery stack. It would be nice if the group could only output one DC voltage as this would greatly simplify the process; however, the group will have to design a circuit that can output variable levels of voltage and current to the battery stack. The group's desire to create a quick and efficient charge necessitates this more complicated requirement. As a result, it will be imperative to have a way to receive feedback from the battery stack and make a decision based on the temperature, voltage, and or current in the battery. Thus, the charging circuitry will require a way to interface with the microcontroller, which will be reading the appropriate sensors at a given interval, in order to make the correct decisions in a timely manner.

Charging the 72V battery stack is not the only on board device that the group must power. Hybrid's Angels will need to also power onboard electronic circuitry on the motorcycle—LED display, microcontroller, etc. As last year's group experienced some issues with the battery system being heavily taxed by the onboard electronics, it will be worthwhile to discuss adding a separate battery instead of drawing the power from the 72V stack, which serves as the primary source of energy to the motorcycle's motor.

4.2.3 CONTROL SYSTEM

For this project, the control system will be the brains behind the operation. It will be extremely important to write robust, functional code as the microcontroller will have to shoulder many important tasks without user intervention. First, it should be able to process the incoming data from various onboard sensors, which include temperature sensors, voltage sensors, and current sensors. Based on the information that is read into the system, this design must give feedback to the appropriately adjust the DC voltage and or current into the 72V battery stack so that the batteries will charge efficiently. Part of the analysis process will also be auto-starting the generator when the batteries are at a level that does not allow for efficient operation. Besides making decisions, it must inform the user of the state of the vehicle via the LED display. Of course, this design must not only be able to make real time decisions

and display them but it also must be able to output formatted data and save it to an external storage for later analysis and use.

4.2.4 MONITORING SYSTEM

4.2.4.1 DATA COLLECTION SUBSYSTEM

The finished product will have a number of sensors at key locations to measure critical data points such as voltages and currents. Some of these are vital for successful real-time operation while others are of more interest in on a historical basis. The data collection subsystem will contain appropriate hardware and software to periodically sample the data from the onboard sensors and record it in an onboard storage device for future retrieval. Both the hardware and software have specific requirements in this subsystem:

Hardware – it must be capable of capturing both analog and digital signals; many of the sensors generate an analog signal between 0 and 5 volts. In addition, it must sample all data inputs quickly to maintain a high sampling rate while not tying up the system resources for extended periods of time. In the same way, the storage scheme must be simple and swift to execute, once again to avoid tying up the system processor during real-time operation. Finally, the subsystem storage capacity needs to be of sufficient size to hold data from a reasonable length ride.

Software – while important, data collection must be a secondary concern to safe and efficient real-time operation. The data collection routines should seamlessly integrate with the critical software functions and should not significantly affect the overall system speed. Wherever possible the system should use standard communication protocols that are easy to understand and debug, such as SPI. Finally, the storage scheme should use the available storage space efficiently while avoiding an extremely complicated methodology.

4.2.4.2 ANALYSIS SUBSYSTEM

Data is not much use until it is transformed into useful information, which is accomplished in the analysis subsystem. Data is transferred from the onboard storage system to a PC where statistical and graphical analysis can take place. There are both hardware and software components to this subsystem:

Hardware – primary component is the physical data link between the microcontroller and the PC. Ideally this will be a wireless data link but a hardware backup will be in place to ensure a reliable connection. The data link will be based on the standard RS-232 protocol

Software – there are two software components to this subsystem. First, on the microcontroller end the software must interface with the storage system and retrieve all the data in an organized fashion and send it through the data link. In addition, the microcontroller software must communicate back and forth with the PC based software to reliably transfer the data. On the PC side the software must capture the incoming data, store it in more permanent hard drive based storage (database) and enable the user to perform statistical and graphical analysis.

4.3 FUTURE ENHANCEMENT REQUIREMENTS

Although of minor importance, the Hybrid's Angels would like to additionally implement a few features to either enhance the safety or mission of the hybrid motorcycle. First and foremost, the group would like to implement a functional headlight, which the user could turn on or off from the control console. To make the design fully street legal, it will also be necessary to install front brakes, a taillight, brake lights, mirrors, and a horn. These devices will require a neat, orderly connection and wiring scheme. In order to further enhance the operation safety, the Lightning Riders indicated that it may be useful to create a physical disconnect on the battery stack, allowing for safer maintenance.

In the spirit of energy economy, the group would also like to implement an alternative energy source to power one of the electronic components. Preliminary thoughts on such an implementation would include utilizing solar technology or better harnessing the energy from the existing regenerative braking system. Incorporating an alternative source will be no small challenge; it will require a proper design to achieve the necessary ratings to power the given electronic device as well as a storage scheme when peak conditions are not present.

5 HIGH LEVEL DESIGN DECISIONS

5.1 GENERATOR

In the group's search for an appropriate generator, they found one that meets all of our specifications. The Gentron Pro2 is a 3500W generator that outputs a 120VAC waveform at a maximum of 25A. It was the smallest electric start generator that could be found by the group, and at dimensions of 23"x18.5"x19", The group is confident that they can successfully mount it on the back of the motorcycle. It has a tank capacity of 3.96 gallons, runs on a cleaner four-stroke engine, and runs for 11 hours at half power. With these statistics, Hybrid's Angels are quite sure that this is the desired generator.

5.2 CHARGING CIRCUITRY AND POWER SUPPLY FOR ELECTRONICS

As discussed above in Section 4, the goal of this circuitry is to first charge the 72V power stack and to secondly provide power to the electronic components on the motorcycle. This objective could be accomplished in a few different ways.

5.2.1 POWER SUPPLY FOR ELECTRONICS

Options for powering the electronics are as follows: 1. DC-DC converter, 2. AC-DC converter, or 3. Separate battery.

The first option would involve converting the 72VDC from the battery stack to the necessary lower voltages using either a custom circuit made by the group or buying a DC-DC converter. After much research, building a DC-DC converter circuit was deemed to be a more in-depth task than initially expected. In order to achieve a high quality, energy efficient design, the group would have to build a complicated circuit using theories that seemed unreasonable for the group given the time frame. In

addition, buying a DC-DC converter for this application proved to be too expensive. For instance, one 72V:12V 400W converterⁱ was found to weigh 3.75lbs and be priced at \$484.28, placing it well out of our budget range. Thus, Hybrid's Angles have decided not to pursue Option 1.

Option 2 involves creating multiple AC-DC converters for the motorcycle. The first would be used to convert the AC wall voltage to the ~90VDC used to charge the batteries. The second would be used to convert the AC wall voltage to 12VDC to power the electronics requiring this voltage or less. A basic resistor bridge could be used to achieve the lower level voltages from this 12VDC point. This process would be achieved by using a transformer with the correct ratio to step down the wall voltage to 12VAC and then feed this through a full bridge rectifier. The general idea is highlighted below in Figure 5.2.1a.

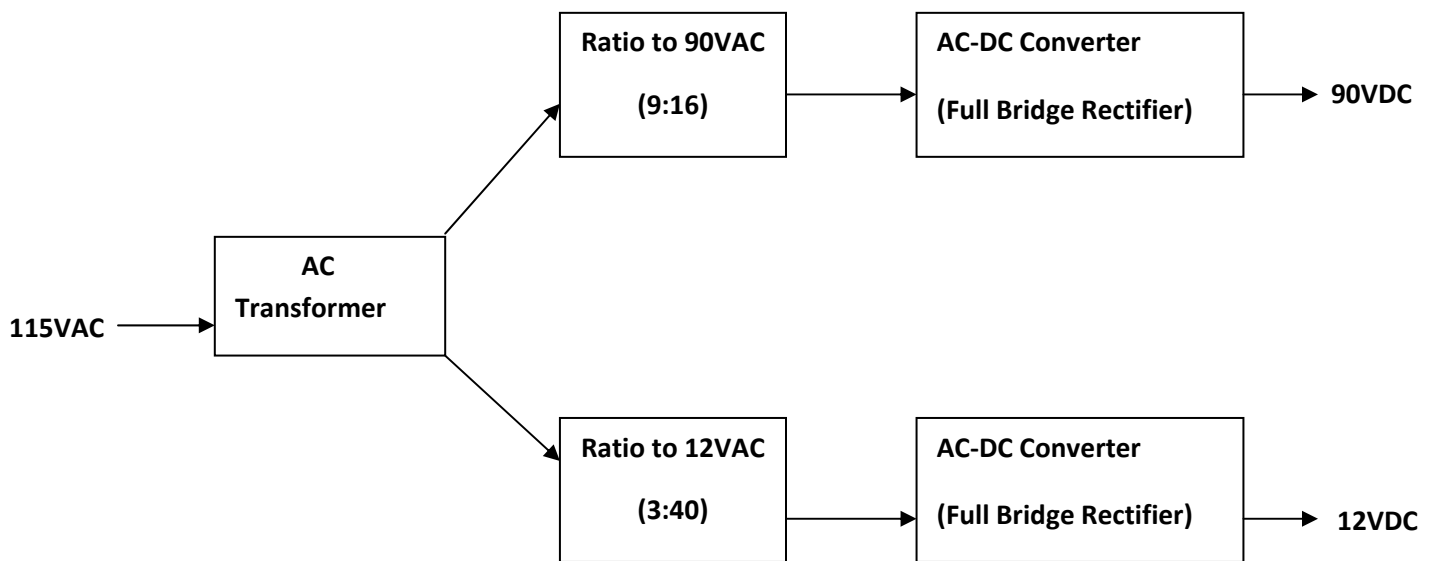

Figure 5.2.1a: Multiple AC-DC converters to power charging circuit and electronics.

Option 3 is to power the electronics using a separate 12V battery. This would involve adding an additional 12V battery with ~1AH capability. Then the electronics could be directly powered from this source or after a small intermediate resistor network to achieve the desired smaller voltages. A way to charge this battery would also have to be implemented, whether it be to charge the battery on the bike or to simply monitor the battery level and then charge it externally when needed. Lead Acid batteries would be the best choice given our technical requirements and financial considerations. Below is a summary of potential candidates that would be suitable for this projectⁱⁱ. All batteries shown, with the exception of the 3.4AH option, weigh equal to or less than 2lbs. As shown, the cost of a 12V battery and the accompanying charger would range from \$34 to \$37. This option is a very viable from both a technical and financial standpoint.

Voltage (V):	Amp-Hours:	Price (\$):	Charger:
12	0.8	19.95	Smart Charger (1.0 A) - \$15.95
12	1.2	16.95	
12	2.3	20.95	
12	3.4	20.95	

Figure 5.2.1b: A-H and Price of Various 12 V Lead Acid Cells

After considering all the above options for a power supply for the electronics, the group has chosen to pursue Option 3. Implementing a separate 12V battery solely devoted to powering the electronics seems to be the most efficient way to control the electronics. Hybrid's Angels has decided that the DC-DC converter (Option 1) would not be the best way to proceed because the cost and size of a buying a new one would not be feasible and creating our own circuit may not prove viable in the given time frame due to complexity. Using an additional AC-DC converter (Option 2) would provide a less expensive and simpler option for producing this DC output. However, tapping a single transformer at multiple locations would affect the power being delivered to the battery. Also, the output 12VDC would likely have a ripple that would need consideration. Thus, the group has decided not to pursue this option either. Implementing a separate 12V battery (Option 3) seems to be the most viable solution to the problem. The available lead acid batteries are relatively inexpensive and small. In addition, a customized charger is available. From an engineering and financial standpoint, Hybrid's Angels have decided to pursue Option 3.

5.2.2 CHARGING CIRCUITRY

Options for the charging circuitry are as follows: 1. Using the circuitry, or a variation of that, designed last year by the Lightning Riders, 2. Using an AC-DC circuit with power MOSFET control, 3. Using a transformer-less Pulse Width Modulation design to produce the regulated output.

The first option would be to use the circuitry developed by the Lightning Riders and then make some changes. Last year’s design was described to our group by John Sember, a member of the Lightning Riders. The idea is that a control signal was developed to trigger when to “turn on” the incoming signal from the generator or the wall outlet. The resulting wave is the rectified using an AC-DC converter to produce an output used to charge the battery stack. The process is summarized below.

Figure 5.2.2a: HLD of Lightning Rider’s Charging Circuit

Block Diagram:

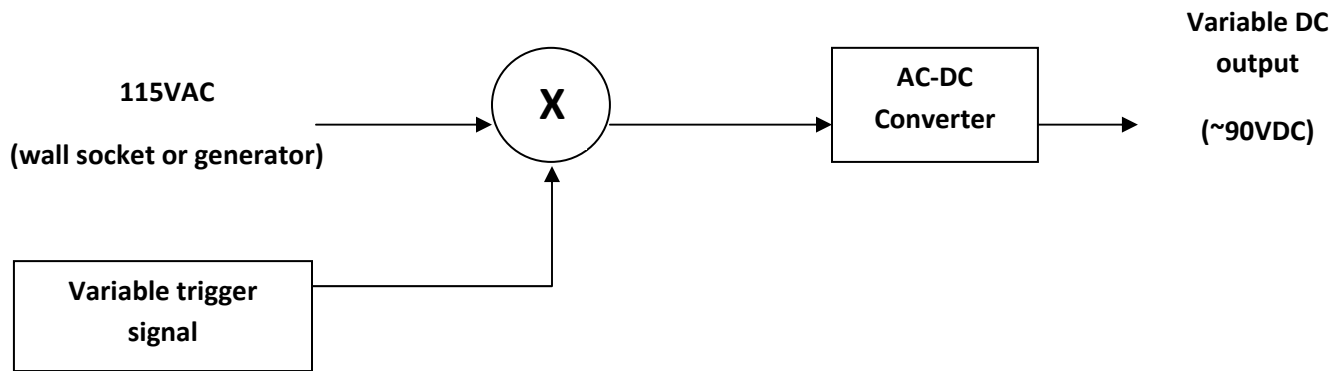

Signals:

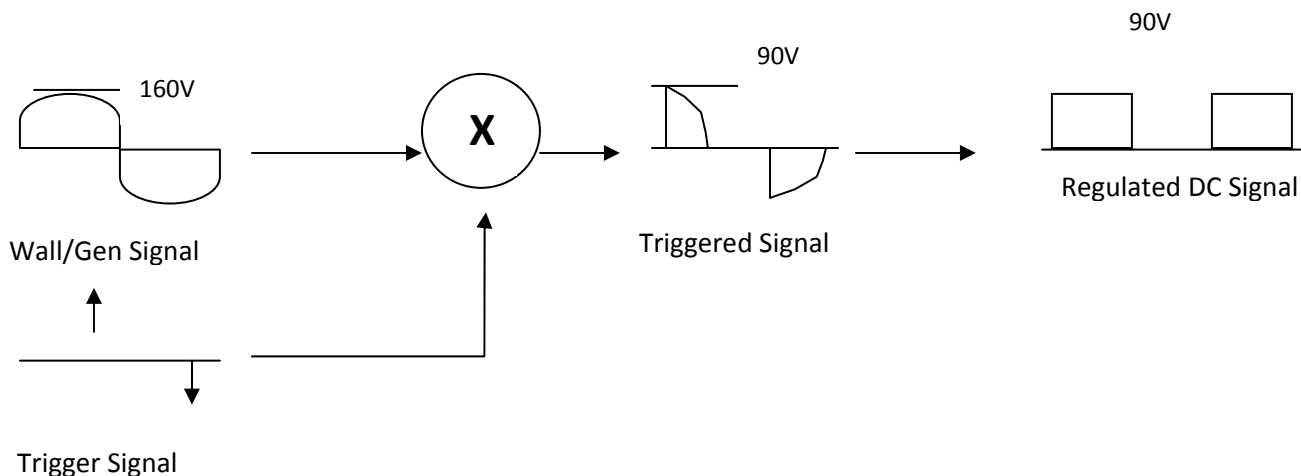

The second design option uses an AC-DC converter followed by a power MOSFET to provide a controllable DC signal to charge the battery. The incoming signal from the wall socket or generator would be stepped down using a customized transformer. The resulting AC signal would then be rectified using a full bridge rectifier. This design would be followed with an RC network to smooth the resulting DC signal. The resulting DC signal would be finely controlled by placing it across a power MOSFET, which would have its gate controlled by the microcontroller. The MOSFET would act as a variable resistor to regulate the voltage and current being applied to the battery stack. The MOSFET would be changed based on inputs, such as the state-of-charge, to the microcontroller. This process is summarized below in Figure 5.2.2b.

Figure 5.2.2b: Design Option 2

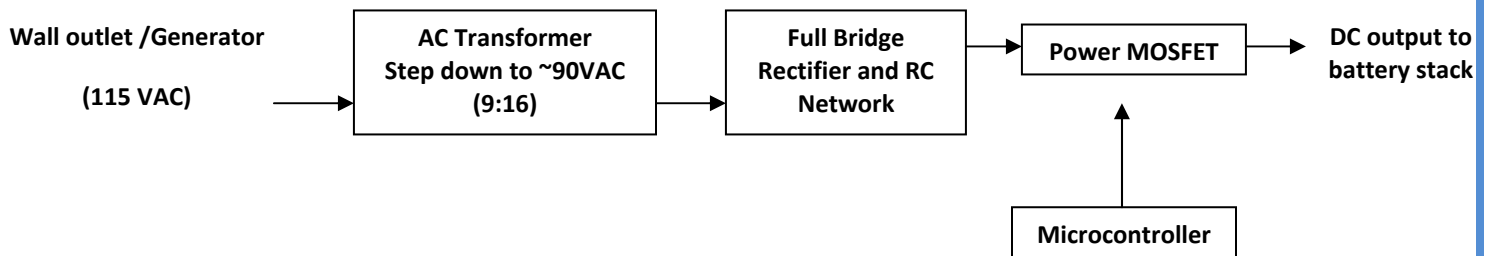

The third option involves using a transformer-less PWM design method to create a variable output DC voltage from the wall socket or generator input. This design was discovered from Apex Microtechnology Corporation's website. It would need to be modified at a lower level to be implemented with the motorcycle but the high level ideas are the same. First, the wall socket or generator signal is fed to an AC-DC converter. At the same time, an input control voltage is fed into an integrator to provide a regulatory signal. These two signals are then fed into a PWM amplifier. This PWM amplifier produces a pulsed signal with a controllable frequency based on the integrated input control signal. Then, this output is fed through multiple low pass filters in order to isolate the DC components and attenuate the high frequency harmonics. The result is a programmable DC power supplyⁱⁱⁱ. The high level idea is summarized below in Figure 5.2.2c.

Figure 5.2.2c: Option 3

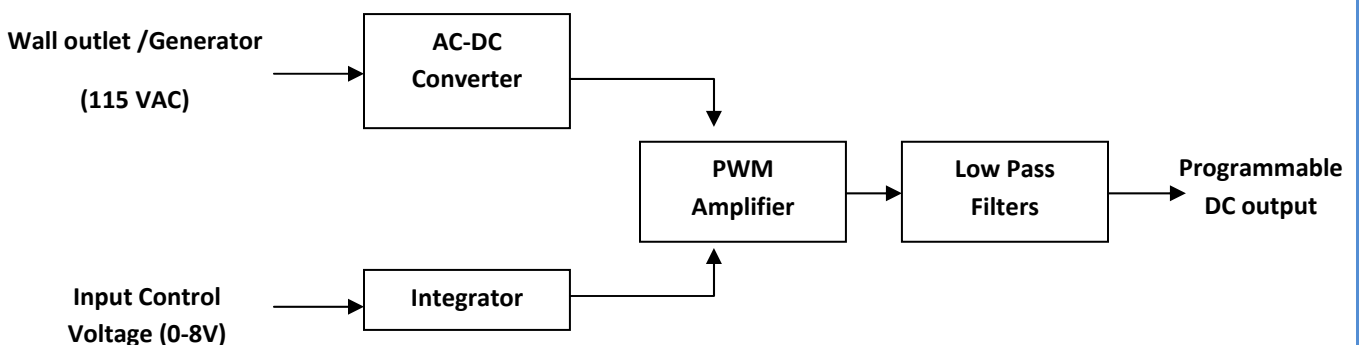

After careful consideration of all three options, the group has decided to pursue the second option. The circuit produced by last year's team (Option 1) was deemed unnecessarily complicated in its design. It does provide a controllable DC output as desired but the design may not be as efficient as possible. Using the transformer-less PWM design (Option 3) initially seemed a very good choice as it provides a stable and controllable DC output. However, Apex did some testing that showed an initial spike in output voltage to 160V before the signal settled to the desired output. Additional filtering would be necessary to ensure that this voltage spike did not damage the battery stack as it cannot handle this large of a voltage. Thus, Hybrid's Angels have decided to pursue Option 2: using an AC-DC converter followed by a controlled power MOSFET. This design would give the group direct control of the output signal in a relatively straightforward fashion. Hybrid's Angels have confirmed that power MOSFETs with the desired ratings (>100V and >10A) are available from such companies as STMicroelectronics^{iv} so finding the correct part should be feasible. One concern is the power that will be wasted in using the MOSFET as a variable resistor; however, by implementing a customized transformer, the group should be able to minimize the power dissipation needed at the MOSFET stage. It is of slight concern to the group regarding the feasibility of implementing a transformer from both a physical and financial perspective. If this issue cannot be solved in an efficient manner, the group will have to reconsider moving towards the PWM design (Option 3). Because of the simplicity of design and ideally efficient nature, the group does not want to prematurely disregard such an idea.

As a final consideration, a 72V 10A high frequency charger for electric vehicles was found to be available^v. This charger costs \$745 which makes it very unreasonable from a financial standpoint. Hybrid's Angels believe that the group can make a more cost efficient design that will provide the same result.

5.3 CONTROL SYSTEM

Both the control system and the monitoring system are software modules which will be implemented on the same microcontroller. For the group's project, they will use the microcontroller that the Lightning Riders used last year. This decision will save the group time and money because the hardware is already mounted onto the bike and working properly. There are also some basic software functions that have already been written for this microcontroller that the group can alter accordingly to meet the new design specifications.

The control system will process the data gathered from sensors around the bike. Using this data, the microcontroller will be able to calculate values such as power used and produce an estimate of how much running-time is left on the batteries. It will also be programmed to constantly monitor the state of the bike to make sure it is running properly and safely. If the batteries get too hot or start to pull too much current, it will trigger an interrupt in the control system software to deal with this issue.

While the batteries are charging, either from a wall outlet or the generator, the control system software will regulate the voltage seen by the batteries. To do this, the microcontroller will directly control the output voltage of the power MOSFET by varying the voltage on the gate. By carefully

monitoring the voltage and current of the charging circuitry, the control system will be able to charge the batteries efficiently without any dangerous voltage spikes.

Another function of the control system will be to receive, process, and send data to the user interface. While the bike is on, the LCD screen will display useful information such as the speed and the estimated charge left in the batteries. The control system is also in charge of monitoring the buttons and switches of the user interface so that any input from the driver is processed quickly. For simplicity sake, the buttons and LCD screen left on the bike by the Lightning Riders will be used. There will be buttons to control the generator, flip through information on the LCD screen, and capture other user inputs. Because the group will be using the same display as the Lightning Riders, the group will currently maintain the screen output generated by the group as seen in the figure below.

MAIN SCREEN															
R	P	M	:						X	X	X	X			
S	O	C	%	:							X	X			
S	O	C		R	A	N	G	E	:	X	X	X	m	i	
F	U	E	L	%	:						X	X			
P O W E R F L O W															
B	A	T	T	:	+-	X	X	X	.	X		a	m	p	s
G	N	T	R	:	+-	X	X	X	.	X		a	m	p	s
M	O	T	R	:	+-	X	X	X	.	X		a	m	p	s

Figure 5.3.a: Screen Display Example from Lightning Riders HLD

Software Flow Description:

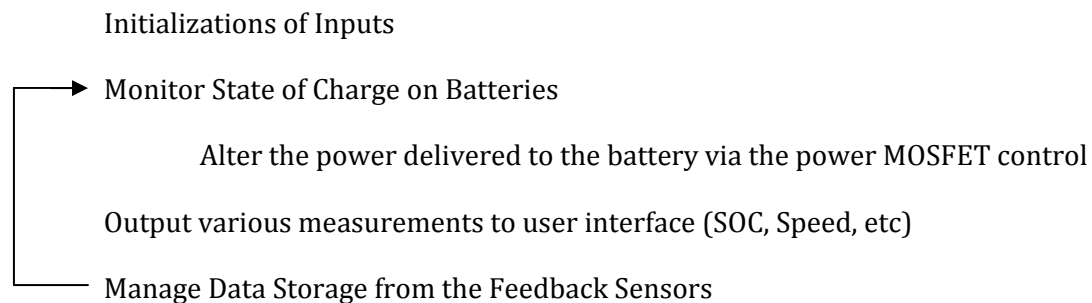

Interrupts:

Input from user buttons

Warnings

5.4 MONITORING SYSTEM

5.4.1 DATA STORAGE SUBSYSTEM

Embedded storage comes in a number of different flavors so there are a number of options available. We have chosen to go with an SPI protocol device based on the simplicity of the interface and the prevalence of such devices. The interface is fast and scalable to our needs by simply using additional chip select lines. In addition, we will likely be using this interface already for data capture so it is a logical step to use it in another application as well. Finally, a number of devices exist at very low cost that should have sufficient storage capacity to meet our needs.

RS-232 is a standard communication protocol for PC to microcontroller communications and has proven to be a reliable interface between the two. Many microcontrollers ship with a USART hardware/software and it is easy to implement on the PC end with programs as simple as HyperTerminal. We hope to use a Serial-Wifi solution offered by Lantronix to make this serial link wireless; although the actual connection is through an 802.11b/g connection the PC will see it as a standard serial port connection. This gives us a number of advantages of 802.11b/g while maintaining the simplicity of a serial connection. The cost of the component (free as a donation) makes it an attractive option to implement with an appropriate hard-wired backup in case of signal failure.

5.4.2 DATA ANALYSIS SUBSYSTEM

Once the data is transferred to the PC from the microcontroller it will be captured in a custom application written using one of the MS Visual Studio languages and stored in a database for further review. The development tools for these languages are readily available online at no cost to the user along with extensive tutorials and how-to guides for the novice user. The ability to program in Visual Studio is a valuable skill and well worth the time to learn. It is an industry-standard software environment and the skills learned during the course of this project are easily transferred to other applications.

6 OPEN QUESTIONS

Hybrid's Angels does have one major unanswered question: the feasibility of incorporating a transformer into the design. The group desires to incorporate a transformer into the design because of the one to one power ratio on the input and output side. Although inherent losses in the transformer will naturally be present, the group feels that a transformer would be a better alternative than just burning all the excess power in a power MOSFET. Unfortunately, the group has some concern that step down transformers capable of handling this amount of power will not be able to realistically be implemented from both a physical and financial perspective. As it stands, the group is currently placing quotes for such transformers with various companies to determine the feasibility. In addition, the group is also looking into making its own transformer for this purpose.

Of lesser concern, the group will need to test balance issues that will result from placing a 110 pound generator on to the back of the cycle. This issue should be easy to test in the future by strapping the

appropriate weight to the back of the cycle. Regardless, this design still seems more feasible than mounting two 75 pound generators on each side of the cycle.

7 MAJOR COMPONENT COSTS

Item:	Plus:	Less:
Class Budget	\$500	
Gigot Center Winnings	\$375	
Generator		(\$400)
Transformer		(\$250)
Charging Circuitry		(\$100)
Steel for Generator Mounting		(\$100)
Selling Two Generators	\$200	
Energy Center Funding	\$?,???	
Unanticipated Costs		(\$200)
Total:	\$25	

8 CONCLUSIONS

Converting an electric motorcycle into a fully-functioning hybrid vehicle is by no means an easy feat. The Hybrid's Angels are faced with a multitude of problems and design challenges. This high-level design document is the group's first attempt at addressing these issues and finding viable engineering solutions to the problems. Naturally, the complexity of this system merits a great deal of careful planning, and the group strongly believes that they are well on their way to success.

Next in the planning process is the low-level design in which the group will explicitly detail the various interconnections and components outlined in this document. Until then, however, the group will continue to research the best ways to fabricate and implement these components in order to achieve a fully functional series hybrid electric motorcycle.

9 REFERENCES

9.1 LIGHTENING RIDER'S HLD

<http://seniordesign.ee.nd.edu/2007/Design%20Teams/Lightning%20Riders/documentation.html>

9.2 GENERATOR

<http://www.generatordepot.us/index.asp?PageAction=VIEWPROD&ProdID=56>

9.3 TRANSFORMER WEB SITES

<http://www.otds.co.uk/transformers.php?gclid=CNvwwOmUyZYCFSMgDQodeE9oLQ>

<http://www.110220volts.com/Merchant2/merchant.mvc?page=110220volts/CTGY/POWER&gclid=CLuqmPbZyJYCFQZeswod7zZSyg>

<http://www.surplustransformers.com/?gclid=CMysz7HbyJYCFQIMswodWkkyw>

9.4 72V DC CHARGER FOR ELECTRIC VEHICLES

<http://www.everything-ev.com/72v-10a-high-frequency-charger-for-onboard-use-p-263.html>

9.5 STAINLESS STEEL PRICES

<http://www.quickshipmetals.com/304-stainless-steel/34food-grade-stainless-steel-sheet-024.html>

<http://www.bsheetmetal.com/sheet-metal-sheets/stainless-steel-sheetmetal.html>

9.6 CHARGING CIRCUITRIES

www.discovercircuits.com

http://www.cirrus.com/en/pubs/appNote/Apex_AN35U_A.pdf?guid=&item_id=&f_page=

<http://www3.telus.net/chemelec/Projects/Charger/Charger.htm>

<http://www.uoguelph.ca/~antoon/circ/batmon12.htm>

<http://www.uoguelph.ca/~antoon/circ/lader.htm>

9.7 ELECTRONICS PARTS

<http://www.rohm.com>

<http://digkey.com/>

<http://www.mouser.com>

<http://www.vicor-asia.com/products/configurable/vipac/>

<http://www.everything-ev.com>

ⁱ Device found on everything-ev.com

ⁱⁱ Battery prices are found from batteryspace.com.

ⁱⁱⁱ Apex's specific design can be found at

http://www.cirrus.com/en/pubs/appNote/Apex_AN35U_A.pdf?guid=&item_id=&f_page=.

^{iv} http://www.st.com/stonline/products/families/transistors/power_mosfets/power_mosfets.htm

^v Everything-EV.com